

# RC7310

## High Speed Driver

### Features

- High output slew rate (1.2 V/ns minimum)
- Wide output voltage range (-3.0V to +8V), and up to 10 Vp-p swings
- 250 MHz minimum operation for ECL swings
- Wide input common mode range for ease of interface to ECL as well as TTL and CMOS
- Output short-circuit protection with current limiter and thermal shutdown
- 100 mA dynamic switching current drive
- Absolute slew rate control
- Low output voltage offset (30 mV typ.) and output offset drift (0.1 mV/°C typ.)
- Low input bias current (1  $\mu$ A typ.) and current drift (40 nA/°C typ.) for output level program voltage allows direct coupling to a DAC output
- Available in 28-pin PLCC

### Applications

- Differential line driver/receiver
- Precision waveform generator
- Level translator
- Switch driver
- Laser driver
- CRT preamplifier

### Description

The RC7310 is a low cost High Speed Driver capable of over 250 MHz operation at ECL levels and greater than 1.2 V/ns slew rate for 5 Vp-p output. The driver offers programmable output levels between -3.0V and +8V and an output amplitude up to 10 Vp-p. It is therefore capable of driving any logic family such as ECL, TTL and CMOS. The high and low limits of the output swing are set through the program pins  $V_H$  and  $V_L$ , respectively. The transfer characteristic from the program pins to the output pin is unity gain with low offset (30 mV typical) and offset drift (0.1 mV/°C typical). The  $V_H$  and  $V_L$  inputs have been buffered to operate with low bias currents (1.0  $\mu$ A typical) allowing direct coupling to the output of a DAC.

The RC7310 is normally driven by ECL levels. However, the input common mode range, -2V to +6V, is wide enough to accommodate TTL or CMOS input signals. When driven with a single ended signal the other input of the RC7310 must be tied to the appropriate threshold voltage.

The RC7310 is specified at nominal power supply values of 10V and -5.2V, and commensurate output voltage swing limits of -3.0V and +8V.

### Block Diagram

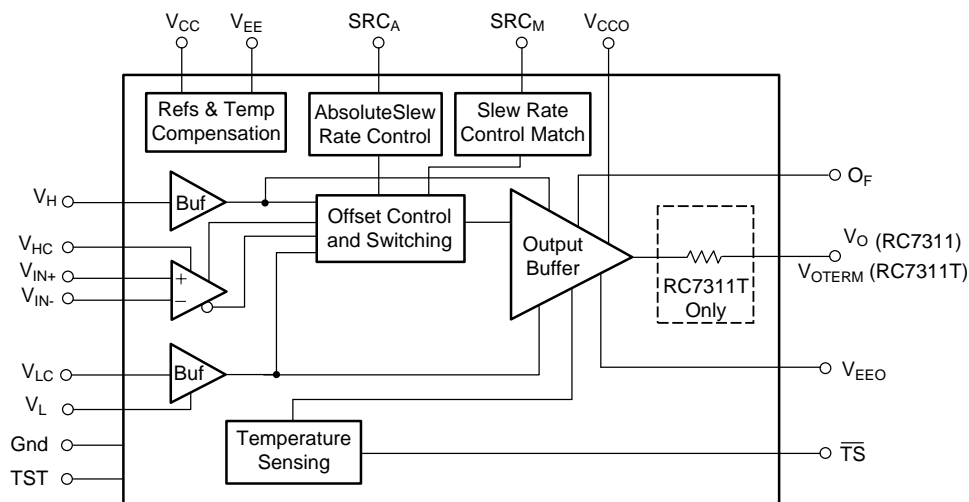

65-7310-01

## Description (continued)

The supply rails may be raised by 2V to achieve an output high level ( $V_{OH}$ ) of +1.0V, or lowered by 2V to achieve an output low level ( $V_{OL}$ ) of -5V. At all times there must be at least a 2V margin between the positive supply and the maxi-

imum value of  $V_{OH}$ , and between the negative supply and the minimum value of  $V_{OL}$ .

The RC7310 is implemented using Raytheon's high performance precision Complementary Bipolar Process (CBiP).

## Pin Assignments

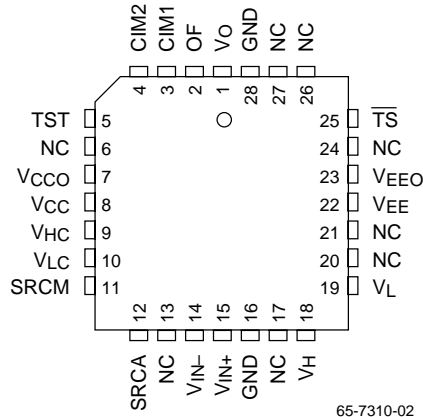

65-7310-02

## Pin Definitions

Pin Name	Pin Number	Pin Function Description
CIM1, CIM2	3, 4	An optional 10,000 pF chip capacitor could be placed between CIM1 and CIM2 to improve impedance matching across different voltage swings. With this capacitor, output impedance stays more constant with changes in voltage swings. If not used, leave pins CIM1 and CIM2 open.
GND	16, 28	Chip ground. These pins should be connected to the printed circuit board's ground plane at the pins.
OF	2	On chip filter to improve output waveform (optional). This pin connection is optional and should be left unconnected if not used. When used, the OF pin should be fed to the termination node that is directly connected to the DUT.
SRCA	12	Absolute slew rate control. By applying current at this pin, small changes in slew rate can be programmed with an external DAC. This control pin affects both positive and negative edge rates. If this slew rate control is not desired this pin should be left open.
SRCM	11	Slew rate control matching. By applying current at this pin, small changes in slew rate can be programmed with an external DAC. This control pin adjusts the match between positive and negative edges. If this slew rate control is not desired this pin should be left open.
$\overline{TS}$	25	Active low output notifies thermal shutdown has occurred. In the event of a short-circuit or other fault that causes the die temperature to rise between 115°C and 160°C, the thermal shutdown will activate. If the fault persists, the device will toggle back and forth between shutdown and normal operation at a frequency in the tens of Hertz. $\overline{TS}$ is an open collector output capable of driving two standard TTL loads. The $\overline{TS}$ pins of several drivers may be wired together and input to a latch to indicate an alarm condition.
TST	5	Pin used for factory testing the thermal characteristics of the device. The pin should be left unconnected or tied to GND.

**Pin Definitions** (continued)

Pin Name	Pin Number	Pin Function Description
VCC	8	Quiet positive supply. The nominal value is 10V $\pm$ 3%. For output high voltage levels (VOH) greater than the nominal value of +8V, VCC should be raised 2V above the maximum VOH value. Whenever VEE is lowered to provide margin at the output low level, VCC should also be lowered by the same amount. VCC should be bypassed to the ground plane with a 10,000 pF chip capacitor placed as close to the pin as possible.
VCCO	7	Positive supply for the output stage. This supply is brought out separately to minimize the supply noise generated when the output switches. VCCO should be bypassed to the ground plane with a 10,000 pF chip capacitor placed as close to the pin as possible and then immediately connected to VCC.
VEE	22	Quiet negative supply. The nominal value is -5.2V to $\pm$ 5%. For output low voltage levels (VOL) less than 3V, VEE should be lowered 2V below the minimum VOL value. Whenever VCC is raised to provide margin at the output high level, VEE should be raised by the same amount. VEE should be bypassed to ground with a 10,000 pF chip capacitor placed as close to the pins as possible.
VEEO	23	Negative supply for the output stage. This supply is brought out separately to minimize the supply noise generated when the output switches. VEEO should be bypassed to the ground plane with a 10,000 pF chip capacitor placed as close to the pin as possible and then immediately connected to VEE.
VH	18	Analog program input that sets the output high level (VOH). The transfer characteristic from VH to VOH is nominally unity gain.
VHC	9	Bypass for analog program input high, VH. VHC should be bypassed to the ground plane with a 1000 pF chip capacitor placed as close to the pin as possible.
VIN+, VIN-	15, 14	Differential digital inputs. The output will toggle between the two levels dictated by VH and VL as the differential signal is switched. Although these inputs will normally be driven by ECL signals, they have a wide enough common mode range that any one of the inputs may be driven by a TTL or CMOS signal provided that the other input is tied to the appropriate threshold voltage.
VL	19	Analog program input that sets the output low level (VOL). The transfer characteristic from VL to VOL is nominally unity gain.
VLC	10	Bypass for analog program input low, VL. VLC should be bypassed to the ground plane with a 1000 pF chip capacitor placed as close to the pin as possible.
VO	1	Driver output of RC7310. The output impedance is 12.6 $\Omega$ $\pm$ 1.5 $\Omega$ . The output is usually back terminated in the characteristic impedance of the driven transmission line. For a 50 $\Omega$ line, a 37.4 $\Omega$ $\pm$ 1% or better resistor should be placed externally as close to the output pin as possible to minimize reflections and ringing. The resistor should also be able to dissipate 0.8W to sustain the short circuit current of the output.
NC	6, 13, 17, 20, 21, 24, 26, 27	No connection.

## Absolute Maximum Ratings<sup>1</sup>

Parameter		Min.	Max.	Unit
Positive power supply, $V_{CC}$			13	V
Negative power supply, $V_{EE}$			-8.2	V
Difference between $V_{CC}$ and $V_{EE}$			16	V
Input voltage at $V_{IN+}$ , $V_{IN-}$	$V_{CC}$	-12		V
	$V_{EE}$		+12	
Input voltage at $V_H$ , $V_L$	$V_{CC}$	-13		V
	$V_{EE}$		+13	
Differential input voltage, $ V_{IN+} - V_{IN-} $			6	V
Difference between $V_H$ and $V_L$ , $( V_H - V_L )$			13	V
Driver output voltage	$V_{CC}$	-13		V
	$V_{EE}$		+13	
Output voltage at $\overline{TS}$			7	V
Duration of short-circuit to ground		Indefinite		
Operating temperature range		0	70	°C
Storage temperature range		-65	+125	°C
Lead temperature range (soldering 10 seconds)			300	°C

### Notes:

1. Absolute Maximum Ratings are those beyond which the safety of the device cannot be guaranteed. They are not meant to imply that the device should be operated at these limits. If the device is subjected to the limits in the absolute maximum ratings for extended periods, its reliability may be impaired. The tables of Electrical Characteristics provide conditions for actual device operation.

## Operating Conditions

Symbol	Parameter	Min.	Typ.	Max.	Unit
TC	Case operating temperature <sup>1</sup>	0		70	°C
VCC	Positive supply voltage	9.7	10.0	10.3	V
VEE	Negative supply voltage	-5.45	-5.2	-4.95	V
VCC – VEE	Difference between positive and negative supply		15.2	15.8	V
VOH, VOL	Range for output high level and output low level	VEE+2		VCC–2	V
VOH – VOL	Output amplitude	0.4		10.0	V
RT	Output back-termination resistor for RC7310		37.4		Ω

### Note:

1. With air flow >300 lfpm.

## DC Electrical Characteristics

VCC = 10V ±3%, VEE = -5.2V ±5%, TA = 25°C (still air), no load, unless otherwise specified.

Symbol	Parameter	Test Conditions	Min.	Typ.	Max.	Unit
<b>Differential Inputs, VIN+, VIN–</b>						
VIN+, VIN–	Absolute Input Voltage		-2.0		+6.0	V
VID	Differential Input Range	VIN+ – VIN–	0.4	ECL	5.0	V
IIN+, IIN–	Bias Current	-2V ≤ VIN± ≤ +6V		-100	-250	μA
<b>Absolute SLR Control, SRCA</b>						
VSRCA	Compliance Voltage Range	VH = +5V, VL = 0V	-2.3	-1.6	-0.9	V
ISRCA	Control Current Range		-1.0		+1.0	mA
%SLRMax	%SLR Absolute Change	Vcom = -2.0		-20		%
%SLRMax	%SLR Absolute Change	Vcom = -2.4		-40/+25		%
<b>Matching SLR Control, SRCM</b>						
VSRCM	Compliance Voltage Range	VH = +5V, VL = 0V	0.4	0.6	0.9	V
ISRCM	Control Current Range		-0.5		+0.5	mA
%SLR	Max % SLR Matching Change			30		%
<b>Voltage Program Inputs VH, VL</b>						
VH	VH Range	VCC = 10V, VEE = -5.2V	-1.0		+8.0	V
		VCC = 12V, VEE = -3.2V	+1.0		+10.0	V
		VCC = 8V, VEE = -7.2V	-3.0		+6.0	V
VL	VL Range	VCC = 10V, VEE = -5.2V	-3.0		+5.5	V
		VCC = 12V, VEE = -3.2V	-1.0		+7.5	V
		VCC = 8V, VEE = -7.2V	-5.0		+3.5	V
VA	VOH – VOL	Output Voltage Amplitude	0.40		10	V
IH	Bias Current @ VH	-1.0V ≤ VH ≤ +8V; VL = -3.0V		-1.0	-5.0	μA
IL	Bias Current @ VL	-3V ≤ VL ≤ +5.5V; VH +8.0V		-1.0	-5.0	μA
TCIH	Max. Temperature Drift in IH	VH = 7.0V; 25°C ≤ TA ≤ 70°C; (output not switching)			40	nA/°C
TCIL	Max. Temperature Drift in IL	VL = -2.0V; 25°C ≤ TC ≤ 70°C; (output not switching)			40	nA/°C

**DC Electrical Characteristics** (continued)

$V_{CC} = 10V \pm 3\%$ ,  $V_{EE} = -5.2V \pm 5\%$ ,  $T_A = 25^\circ C$  (still air), no load, unless otherwise specified.

Symbol	Parameter	Test Conditions	Min.	Typ.	Max.	Unit
$\Delta I_{BDC}$	Variation in $I_H$ , $I_L$ with Power Supply and DC Voltage at $V_H$ or $V_L$	$V_H = -1.0V$ to $+8V$ ; $V_L = -3V$ to $+5.5V$	-2.0		+2.0	$\mu A$
$V_{H,LBW}$	$V_{H,L}$ BW	-3 dB point from $V_{H,LBW}$ to $V_{OUT}$		50		kHz
<b>Signal Output <math>V_O</math>, <math>V_{OTERM}</math></b>						
$V_{OH}$	Range for High Level Voltage	$V_{CC} = 10V$ , $V_{EE} = -5.2V$	-1.0		+8.0	V
		$V_{CC} = 12V$ , $V_{EE} = -3.2V$	+1.0		+10.0	V
		$V_{CC} = 8V$ , $V_{EE} = -7.2V$	-3.0		+6.0	V
$V_{OL}$	Range for Low Level Voltage	$V_{CC} = 10V$ , $V_{EE} = -5.2V$	-3.0		+5.5	V
		$V_{CC} = 12V$ , $V_{EE} = -3.2V$	+1.0		+7.5	V
		$V_{CC} = 8V$ , $V_{EE} = -7.2V$	-5.0		+3.5	V
$\delta V_{OH}$	Offset to Output High Level	$\delta V_{OH} =  V_H - V_{OH} $ , $V_H = 0V$ , $V_L = -3V$ , $-1.0V \leq V_H \leq +8V$ , $V_L = -2V$		30	100	mV
$\delta V_{OL}$	Offset to Output Low Level	$\delta V_{OL} =  V_L - V_{OL} $ , $V_H = 8V$ , $V_L = 0V$ , $-3V \leq V_L \leq +5.5V$ , $V_L = +7V$		30	100	mV
VTC	Output Voltage Drift	$-3V \leq V_L \leq +5.5V$ , $-1.0V \leq V_H \leq +8V$		0.1	0.5	mV/ $^\circ C$
$\epsilon_G$	Gain Error	$-3.0V \leq V_L \leq +5.5V$ , $V_H = +8V$ , $-1.0V \leq V_H \leq +7.5V$ , $V_L = -3V$	-1.0		+1.0	% $V_{SET}$
$\epsilon_L$	Linearity Error	$0V \leq V_L \leq +5V$ , $V_H = +8V$ , $0V \leq V_H \leq +5V$ , $V_L = -3V$	-0.3		+0.3	% $V_{SET}$
		$-3.0V \leq V_L \leq +5.5V$ , $V_H = +8V$ , $-1.0V \leq V_H \leq +7.5V$ , $V_L = -3V$	-0.5		+0.5	% $V_{SET}$
Z <sub>OUT</sub>	Output Impedance	$V_O$ (RC7310)		12.6		$\Omega$
I <sub>AC</sub>	AC Current Drive		70	100		mA
I <sub>DC</sub>	DC Current Drive		50			mA
<b>Thermal Shutdown Output (TS)</b>						
V <sub>OL</sub>	Output Low Level	$I_{OL} = 4$ mA			0.5	V
I <sub>CL</sub>	DC Current Limit		70	110	130	mA
TS	Shutdown Die Temperature		115	130	160	$^\circ C$
<b>Other</b>						
I <sub>CC</sub>	Positive Supply Current			60		mA
I <sub>EE</sub>	Negative Supply Current			60		mA
PSR <sub>VO</sub>	Output Level to Power Supply Rejection Ratio	$V_{CC}$ ; $\Delta V_{CC} = \pm 2.5\%$ $V_{EE}$ ; $\Delta V_{EE} = \pm 2.5\%$	40 40			dB dB
PSR <sub>VSL</sub>	Output Slew Rate to Power Supply Rejection Ratio	$V_{CC}$ ; $\Delta V_{CC} = \pm 200$ mV $V_{EE}$ ; $\Delta V_{EE} = \pm 200$ mV			4 4	% %
T <sub>A</sub>	Operating Temperature Range	Still Air	0	25	50	$^\circ C$
		Air Flow > 300 l/fpm	0	25	70	$^\circ C$

## AC Electrical Characteristics

$V_{CC} = 10V \pm 3\%$ ,  $V_{EE} = -5.2V \pm 5\%$ ,  $T_A = 25^\circ C$  (still air) and the load is a  $50\Omega$  transmission line with 2.0 ns one-way delay, unless otherwise specified. The transmission line should be back-terminated in  $50\Omega (\pm 1\%)$  using an external resistor. The measurement probe is a high impedance FET probe with capacitance no greater than 6 pF and resistance no smaller than 10 k $\Omega$ .

Symbol	Parameter	Test Conditions	Min.	Typ.	Max.	Unit
SLR	Slew Rate (SRCM and SRCA Adjusted)	$V_H - V_L = 5V$ ; measured between 20% and 80% points				
		With probe only as load	1.2	1.6		V/ns
		With probe and transmission line	1.1	1.5		V/ns
SLR	Slew Rate (No SRCM and SRCA Adjustment)	$V_H - V_L = 5V$ ; measured between 20% and 80% points				
		With probe only as load	1.0	1.4		V/ns
		With probe and transmission line	1.0	1.4		V/ns
t <sub>R</sub> , t <sub>F</sub>	Rise Time and Fall Time (SRCM and SRCA Adjusted)	Load is Probe Only				
		Amplitude = 0.8V (20% to 80%)		0.6	0.8	ns
		3V (10% to 90%)		1.7	2.0	ns
		5V (10% to 90%)		2.4	2.9	ns
		9V (10% to 90%)		4.0	4.8	ns
t <sub>R</sub> , t <sub>F</sub>	Rise Time and Fall Time (No SRCM and SRCA Adjustment)	Load is Probe Only				
		Amplitude = 0.8V (20% to 80%)		0.7	1.0	ns
		3V (10% to 90%)		2.0	2.4	ns
		5V (10% to 90%)		2.8	3.6	ns
		9V (10% to 90%)		4.8		ns
f	Toggle Rate	Amplitude = 0.8V	250	270		MHz
		Amplitude = 5.0V	105	110		MHz
<b>Propagation Delay</b>						
t <sub>PLH</sub>	Low to High	f = 10 MHz; V <sub>OH</sub> = +0.4V; V <sub>OL</sub> = -0.4V		1.6	2.0	ns
t <sub>PHL</sub>	High to Low			1.6	2.0	ns
$\Delta t_p$	Matching  t <sub>PLH</sub> - t <sub>PHL</sub>			150	175	ps
$\Delta t_{PTC}$	Temperature Coefficient			2		ps/°C
t <sub>PWMIN</sub>	Minimum Pulse Width	V <sub>H</sub> - V <sub>L</sub> = 2.0V; Pulse Width at which amplitude drops by 50mV, measured between 50% points	2.0			ns
$\Delta t_{PPW}$	Propagation Delay Variation with Pulse Width	2ns < PW < 98ns; f = 10 MHz; V <sub>OH</sub> = +0.4V; V <sub>OL</sub> = -0.4V	-75		+75	ps
PS	Preshoot	0.5V <  V <sub>OH</sub> - V <sub>OL</sub>   < 5V		15 mV + 3% of V <sub>A</sub>		mV
OS	Overshoot	0.5V <  V <sub>OH</sub> - V <sub>OL</sub>   < 5V		50 mV + 4% of V <sub>A</sub>		mV
t <sub>S</sub>	Output Setting Time	V <sub>OH</sub> - V <sub>OL</sub>   = 5V				
		To within 3% of  V <sub>OH</sub> - V <sub>OL</sub>		5		ns
		To within 1% of  V <sub>OH</sub> - V <sub>OL</sub>		10		ns

**Notes:**



**Notes:**

**Notes:**

# Mechanical Dimensions

## 28-Lead PLCC

Symbol	Inches		Millimeters		Notes
	Min.	Max.	Min.	Max.	
A	.165	.180	4.19	4.57	
A1	.090	.120	2.29	3.05	
A2	.020	—	.51	—	
B	.013	.021	.33	.53	
B1	.026	.032	.66	.81	
D/E	.485	.495	12.32	12.57	
D1/E1	.450	.456	11.43	11.58	3
D3/E3	.300 BSC		7.62 BSC		
e	.050 BSC		1.27 BSC		
J	.042	.048	1.07	1.22	2
ND/NE	7		7		
N	28		28		
ccc	—	.004	—	0.10	

**Notes:**

1. All dimensions and tolerances conform to ANSI Y14.5M-1982
2. Corner and edge chamfer (J) = 45°
3. Dimension D1 and E1 do not include mold protrusion. Allowable protrusion is .101" (.25mm)

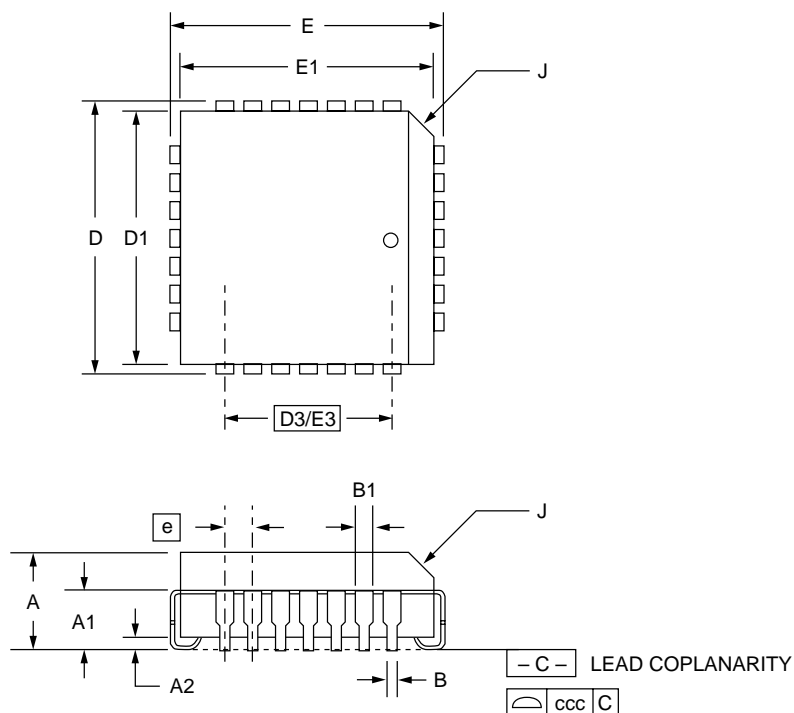

## Ordering Information

Part Number	Package	Operating Temperature Range
RC7310QA	28-Pin PLCC	0°C to +70°C

The information contained in this data sheet has been carefully compiled; however, it shall not by implication or otherwise become part of the terms and conditions of any subsequent sale. Raytheon's liability shall be determined solely by its standard terms and conditions of sale. No representation as to application or use or that the circuits are either licensed or free from patent infringement is intended or implied. Raytheon reserves the right to change the circuitry and any other data at any time without notice and assumes no liability for errors.

### LIFE SUPPORT POLICY:

Raytheon's products are not designed for use in life support applications, wherein a failure or malfunction of the component can reasonably be expected to result in personal injury. The user of Raytheon components in life support applications assumes all risk of such use and indemnifies Raytheon Company against all damages

Raytheon Electronics  
Semiconductor Division  
350 Ellis Street  
Mountain View, CA 94043  
415.968.9211  
FAX 415.966.7742